

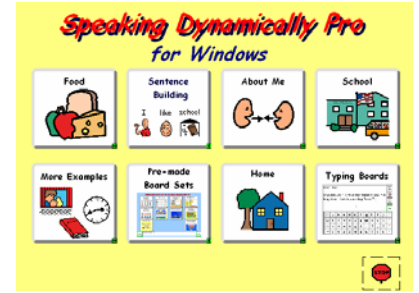

Making Functional Overlays with Boardmaker and Speaking Dynamically Pro

Exploring with Sample Boards

Click on desktop icon “Shortcut to SDPro Main”
Speaking Dynamically Pro main board will come up
Explore for 5 to 8 minutes
Hit escape and red X in the right hand corner to close the program



Creating a Board from Scratch

Launch the Program:

Double click “SDP icon” on your desktop



“funny guy”

Important Keystrokes:

DESIGN mode (Ctrl + D) – will allow for editing and creating boards
USE mode (Ctrl + U) – will allow your boards to talk and perform an action

Getting Started:

“Open a new board” will allow you to customize a board to your student’s specific needs
Click on “open a new board”

*It is very important to save your board once you begin working on it

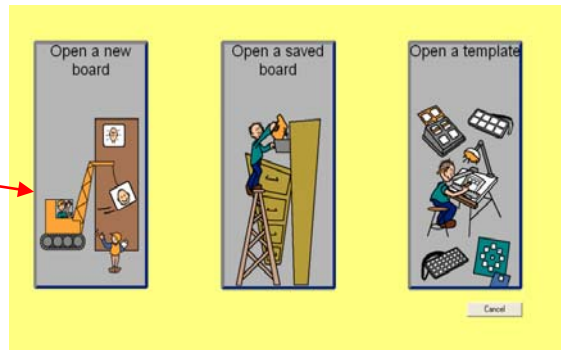

Saving a Board:

File
Save As: “Food choices Tyrone”
Save In: My boards
Tyrone’s folder

Create a Button:

Select the “button tool” in the tool palette

The arrow will turn into a + sign which is referred to as cross hairs

Click and drag your mouse to create a 2 inch by 2 inch square

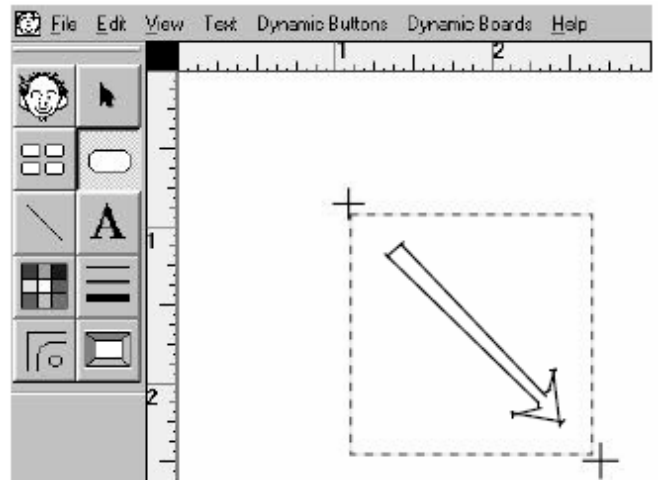

Spraying Buttons:

Click the “button sprayer tool”

Move the button tool over the top of the button

Click and drag diagonally to spray out 8 total buttons

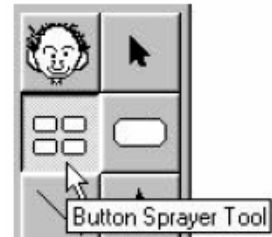

Adding Background Color:



Click on the background

Go to colors and select a color

Pick a background color by clicking on the color

Adding Symbols:

Select the “symbol finder tool” (AKA “funny guy”)

The symbol finder window will appear

Click on the “select categories” button

Click on the “clear all standard categories” button

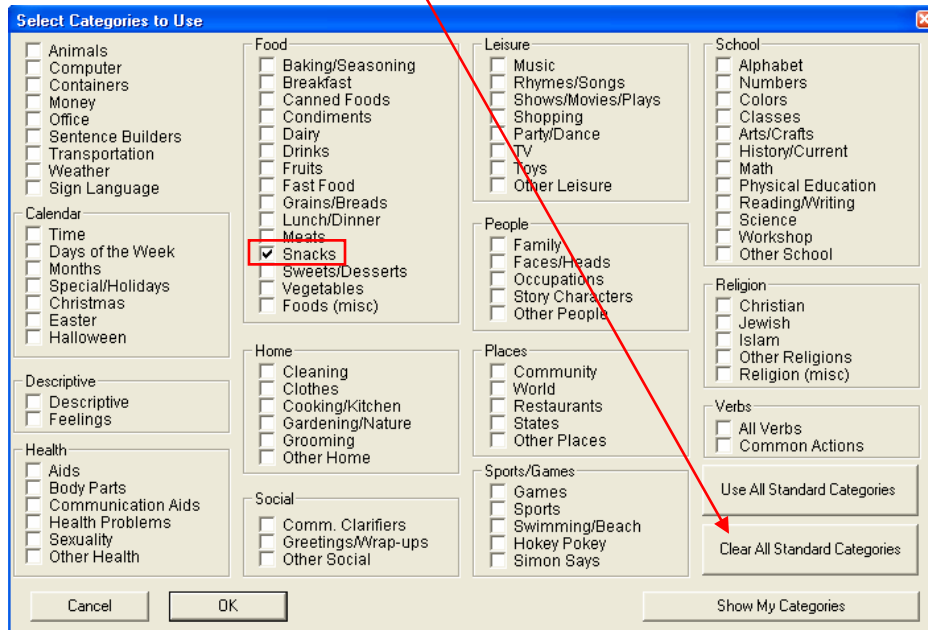
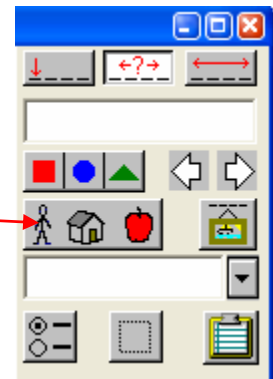

Click on the “snacks” category only

Click OK

Type in the search text field “granola bar”

Click the button to insert the picture of the granola bar

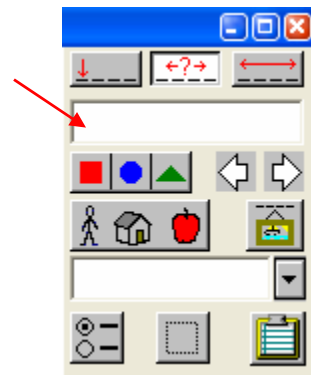

*** Repeat inserting the following pictures:**

jello, peanuts, candy, chips, popcorn, and chocolate pudding



Customizing a Symbol:

Click on “funny guy”
 Type in “I want”
 Use the arrow keys to scroll through the choices
 Stop and insert the girl with the yellow hair
 Click on the symbol
 The symbol editing tool bar will appear
 Click on the eraser



A window will appear asking if you want to convert the file to a bitmap click “yes”

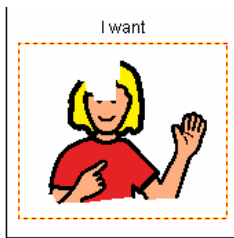
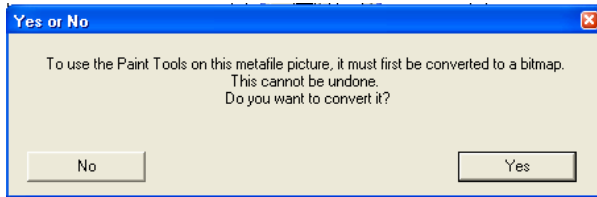

Erase her head
 To get a smaller eraser click on the “thickness tool”



Click the “funny guy”
 Type in “person 62”
 Click and drag over the head and click on the button “I want”
 Click “add to”

Click on the head to resize it

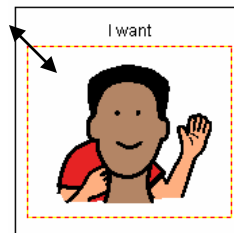
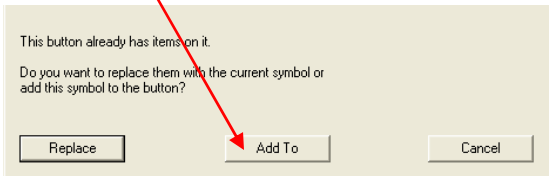

Click the body to change skin color

Click the “fill tool” to paint
Select the color



Your finished button should look like this



***Always remember to save your work every time you make major changes**

Making your boards speak

SDP Boards:

1. Sample Boards
2. Templates – activities, journal board sets, simple communication boards and writing boards

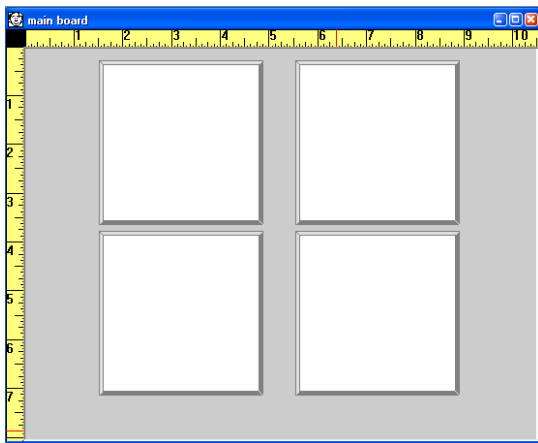

Before you begin to make a main board consider –

1. How many buttons on each board
2. What topics need to be included
3. What vocabulary is needed

Creating a Main Board:

File

Open

Open a “saved board”

Look in: Desk top-

Double click on “SDPro” folder

Click on “main board”

Click “open”

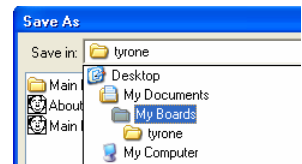

Saving a Board:

Click on “file menu”

Select “save as”

Save in “my boards”

Add “new folder”

Type in “Tyrone” and open file

Type in “main board” and save



Adding Symbols:



Click on “funny guy”

Search for “me” and change words to “about me” click button or hit enter

Search for “food” and click on button

Search for “shoes” change words to “tie shoes” click button

Search for “school” and click on button

Change Background Color:



Click on the background

Go to colors and select a color

Click on the button to change the background for the button

Adding Speech to a Button:

Double click on “about me” icon

The button actions window will appear

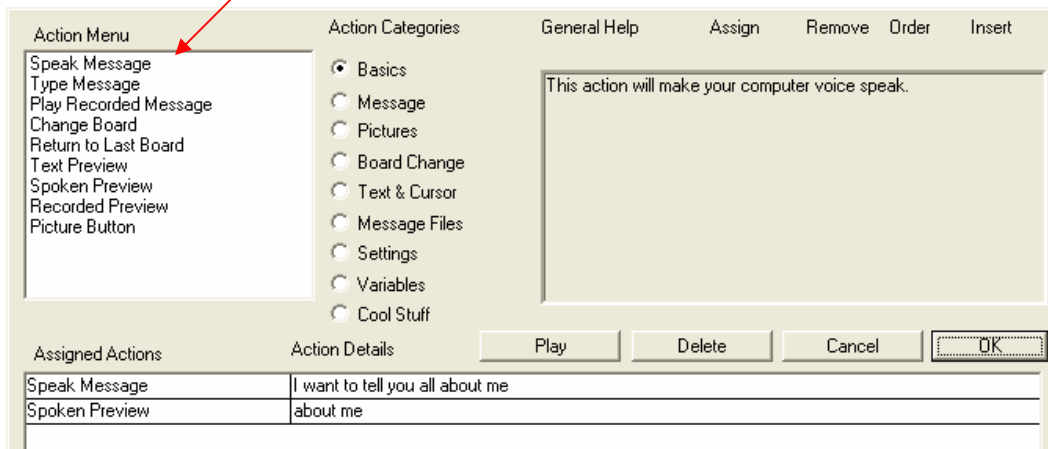

Select “speak message” in the action menu
Type in “I want to tell you all about me”

Click “use button text” if you want it to
speak the text currently on the button

Click “speak” to listen to your message

Select OK

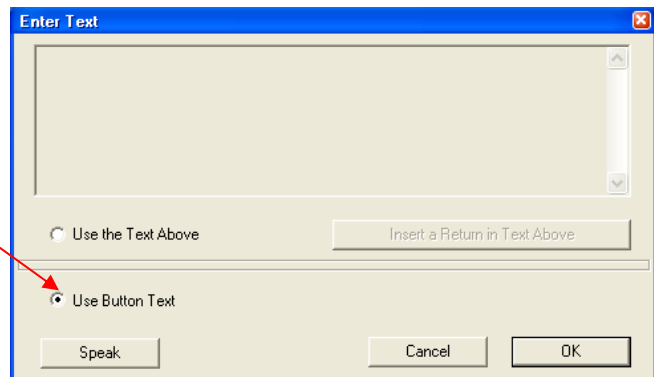

Giving a Button a Spoken Preview:

Double click on “about me” icon

The button actions window will appear

Select “spoken preview” in the action menu

Type in “about me”

*If the spoken preview is the same as the button text you can just click “use button text”

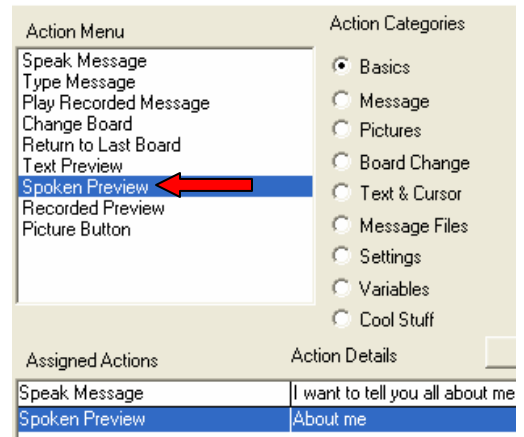

Giving a Button Recorded Sound:

There are two ways to give a button recorded sound

1. By recording the sound through a microphone
2. By playing a saved sound from other boards or retrieving a sound from your computer

Double click on the button “food”

The button actions window will appear

*You must have a sound card with a microphone or a built-in microphone to record sound

Click on “record new sound” button, click on “record”, say into microphone “I’m hungry, I want something to eat”

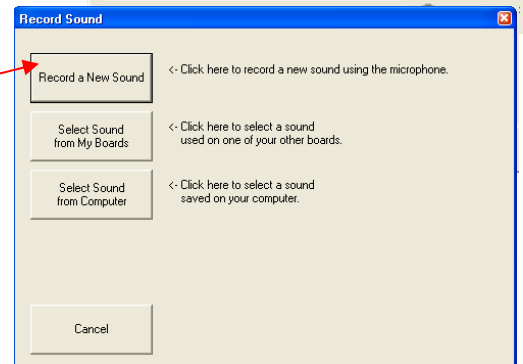
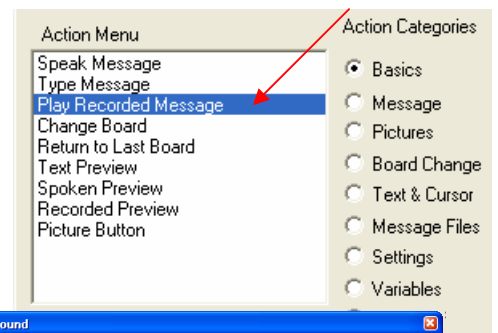

Press “stop”, click OK, and enter the descriptive name for the sound file

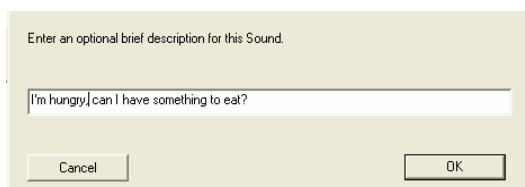

Practice

Program the other two buttons using either **Spoken Preview** or **Recorded Message**

Using and Editing Existing Templates:

File

Open

Navigate to the desktop to the “SDPro” folder

Open “About me”

File

*Save in “Tyrone’s” folder

***Linked boards must be saved in the same folder as the main board**

Save as “About me-Tyrone”

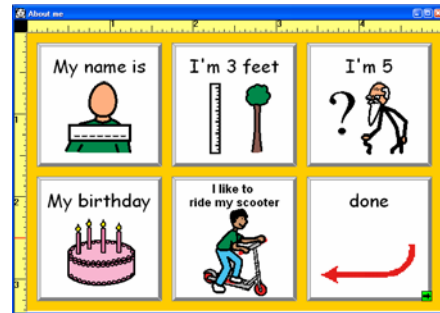

Adding Digital Pictures to Your Boards

Click on the “funny guy”

File

Import

Picture

Look in: SDPro- Highlight Tyrone- click “open”

“My Symbols\Mine” window will appear

You will add a name

Type in “Tyrone”

Click “add a name”

Click “assign categories”

Assign the picture a category “other people”

Click OK

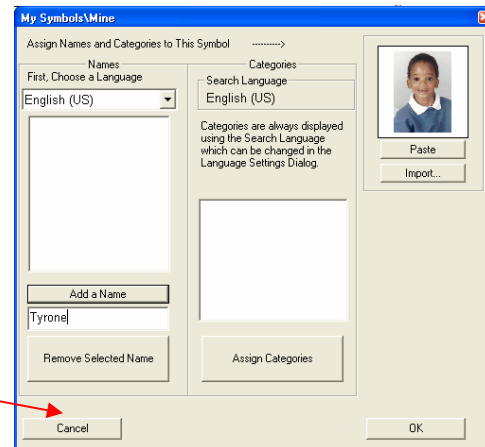

Adding Your Newly Imported Picture

Click on the “funny guy”

Click on the button “My name is”

A window will appear click on “replace”

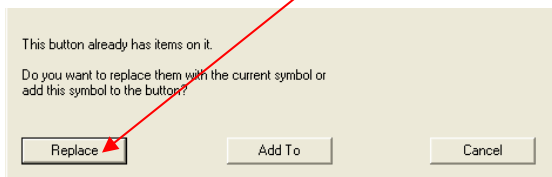

Using Existing Templates to Link Boards:

- Return to the main board
- Double click on the button “about me”
- Double click “change board”
- Click and highlight “About me Tyrone”
- Click OK
- Click OK again

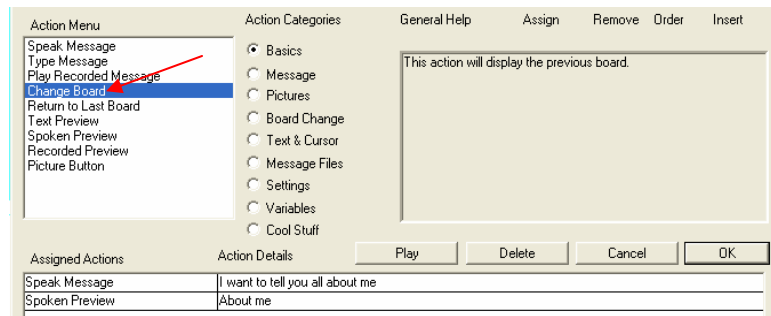

*Green arrow in bottom right corner signifies the button is linked to another board

Change to USE mode (Ctrl + U) to test linked boards.

Practice

File

- Open from “Desktop-SDPro”-“Tie Shoes” board
- Save as “Tie Shoes-Tyrone”
- Save in “My board- Tyrone”
- Link to “Tie Shoes” button

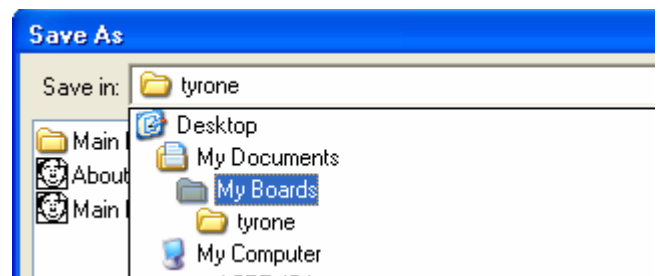

Cool Stuff

Inserting Movies:

- Double click on “tie shoes” button
- Click on “cool stuff”
- Highlight “play movie”

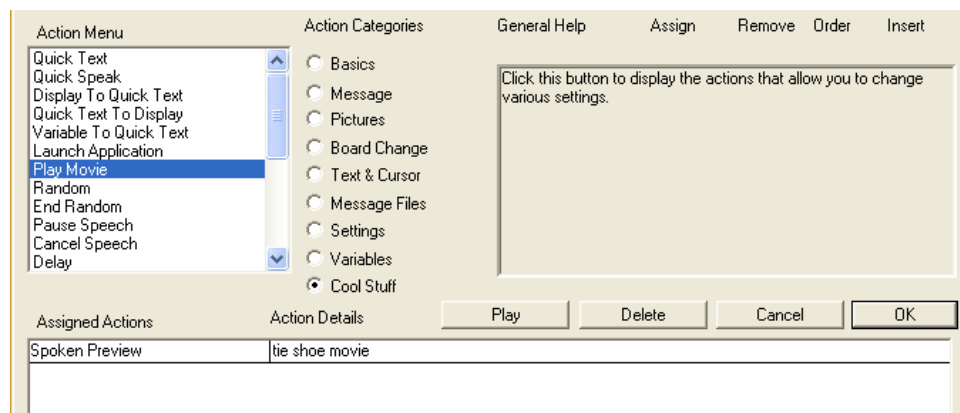

Find “SDPro folder”
 Open “Tie Shoe 3” video
 Click OK
 Change to USE mode (Ctrl + U) to test video

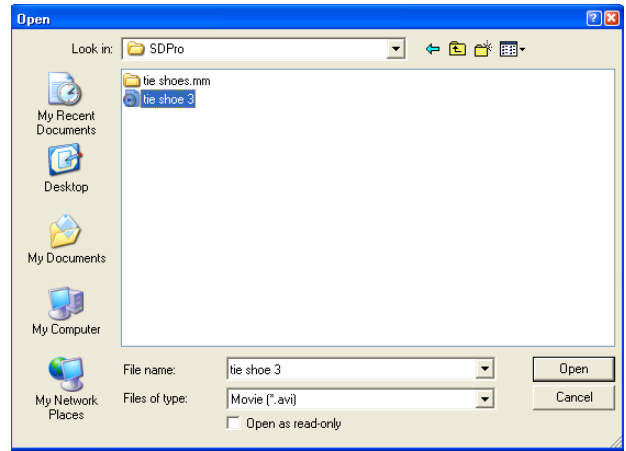

Launching Applications:

Minimize your SDP window
 Open the file “SDPro folder”
 Right click on the file “telephone practice”
 Drag it to the desktop
 Release the mouse and a menu will appear
 Select “create shortcuts here”

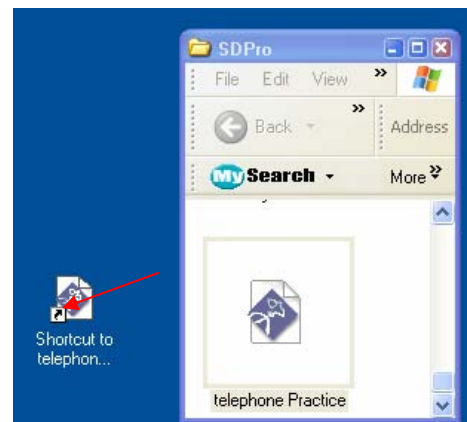
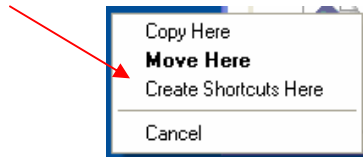

Click on “my computer”
 Open the “C” drive
 Open “program files”
 Open “Boardmaker with SD Pro”
 Right click and drag the file into the SDP externals folder
 Select “move here”



Restoring Your SDPro Window

Maximize your “About me Tyrone” board

Double click on the “phone number” button

Select “cool stuff” under the action categories

Select “launch application”

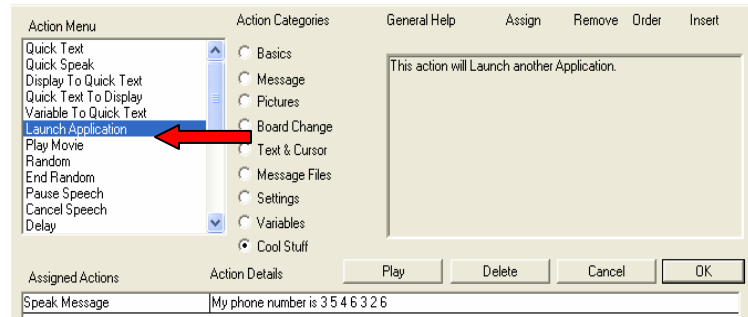

Highlight “shortcut to telephone Practice.Ink” and click OK

Go to the User mode to test your board

